

DRAIN+ COMPACT INSTALLATION INSTRUCTIONS

SHOWER WASTE WATER HEAT RECOVERY SYSTEM



These instructions are to be left with the user.

1. Introduction

The RECOUP Drain+ Compact is a Waste Water Heat Recovery System for shower water (WWHRS). It recovers heat from the warm waste water as it passes through the unit, before going to the drainage system.

The heat recovery is possible due to the double walled heat copper heat exchanger within the Drain+ Compact, a very effective material for transferring heat. The double walled exchanger gives full protection against any contamination between the waste water going out and the fresh potable water coming in. This preheated water then supplies the mains cold feed to the shower and/or a water heater (Combi-boiler, hot water storage cylinder, Thermal store or HIU).

The reason for doing this is to save money and energy. In an average shower, the water will come out of the shower head at 40°C, and the water going down the drain will only be a few degrees cooler than this. This energy has been paid for once, and we believe at RECOUP, that the home owner should get as much benefit from this energy before paying to reheat more water and at the same time reduce the energy consumption and CO₂ emissions of the home.

The RECOUP Drain+ Compact should be installed by a suitably qualified plumber who gives consideration and attention to the system design as well as a correct installation.

The RECOUP Drain+ Compact is a horizontal heat exchanger, and is designed to work with showers positioned within a wet room. It is very important to follow all the instructions for installation of the RECOUP Drain+ Compact for the product to perform successfully.

IMPORTANT – For recognition of the RECOUP Drain+ Compact energy saving performance within the National Calculation Method (NCM) for the energy rating of a new build dwelling within the UK (also known as the Standard Assessment Procedure (SAP)) it is vital that the following are complied with:-

- a) This Instruction Manual
- b) A system design checklist
- c) Installation checklist
- d) Certificate of installation

Section b, c & d are supplied as a single document and can be downloaded from our website registration page at registration.recoupwwhrs.co.uk or at: www.ncm-pcdb.org.uk/sap – A signed copy of each should:-

1. Be left with the home user pack (for the home owner)
2. Retained by the installer
3. A copy sent to RECOUP Energy Solutions Ltd (See company contact details).

Alternatively you can register the installation with the Recoup WWHRS App. See the registration section. (Note: Building control officers may also request a copy)

A NCM (SAP) identifier label is permanently fixed to the RECOUP Drain+ Compact unit and a second label attached to a nearby water heater or service cupboard. The 'model qualifier' section of the first label denotes the system installation configuration (A, B or C) and will state 'Refer to Installation certificate **otherwise System B will be assumed**'. The actual system configuration will be recorded on the system design checklist, installation checklist/certificate of installation and the second NCM (SAP) identifier label.

2. Product technical data

2.a) General Information – RECOUP Drain+ Compact

Description	Value	Unit
Minimum depth for installation	111	mm
Overall width for installation	860	mm
Material - Heat Exchanger	Copper	
Shower flow rate range	5 - 12.5	Litres/min
Max. Mains water inlet pressure	10	bar
Min. Mains water inlet pressure	1	bar
Max. Mains water working temp	85	°C
Mains water connection	½" male	BSP
Waste water connection	40 - 43	mm
Full product weight (Boxed)	8.5	kg
Water volume - mains water	0.48	Litres

The mains water and preheat connections are a ½" male BSP connector which can be joined to either a 15mm or 22mm pipe with reducer. The waste water connection will fit either a 40mm push-fit or 43mm solvent pipe.

2.b) Performance & Efficiency

Shower Flow Rate @ 40°C (Litres/min)	Drain+ Compact Efficiency (Recovered energy kWh)		
	System A	System B	System C
5.8	39.5% (4.8)		
9.0	38.6% (7.3)	31.0% (5.8)	35.5% (6.7)
9.2	38.1% (7.3)		
11.0	37.0% (8.5)	30.4% (7.0)	33.8% (7.8)
12.5	36.4% (9.5)		

2.c) Pressure drop on main water circuit

Shower Flow Rate @ 40°C (Litres/min)	Drain+ Compact Pressure Drop (bar)		
	System A	System B	System C
5.8	0.07	<0.05	
9.2	0.16	0.10	0.06
12.5	0.25	0.16	0.10

3. Pre-installation requirement

3.a) Basic system principle

The RECOUP Drain+ Compact is a Waste Water Heat Recovery System (WWHRS) for shower water, meaning it recovers heat from the warm waste water from a shower as it passes through before going to the drainage system for the property.

This preheated water then supplies the mains cold feed to the shower and the Domestic Hot Water (DHW) heater or in the case of system configurations System B and System C, the shower or the DHW heater respectively. The DHW heater could be:

- Unvented hot water cylinder
- A combination boiler
- A thermal store (Mains pressure DHW delivery)
- A Heat Interface Unit (HIU) on a district heating scheme (Mains pressure DHW delivery)

Note: The DHW heater must be a mains pressure system and able to accept preheated cold water.

3.b) Installation configuration

The inlet for the RECOUP Drain+ Compact is connected to the mains water supply, and the outlet (preheated water) can be connected in one of three ways.

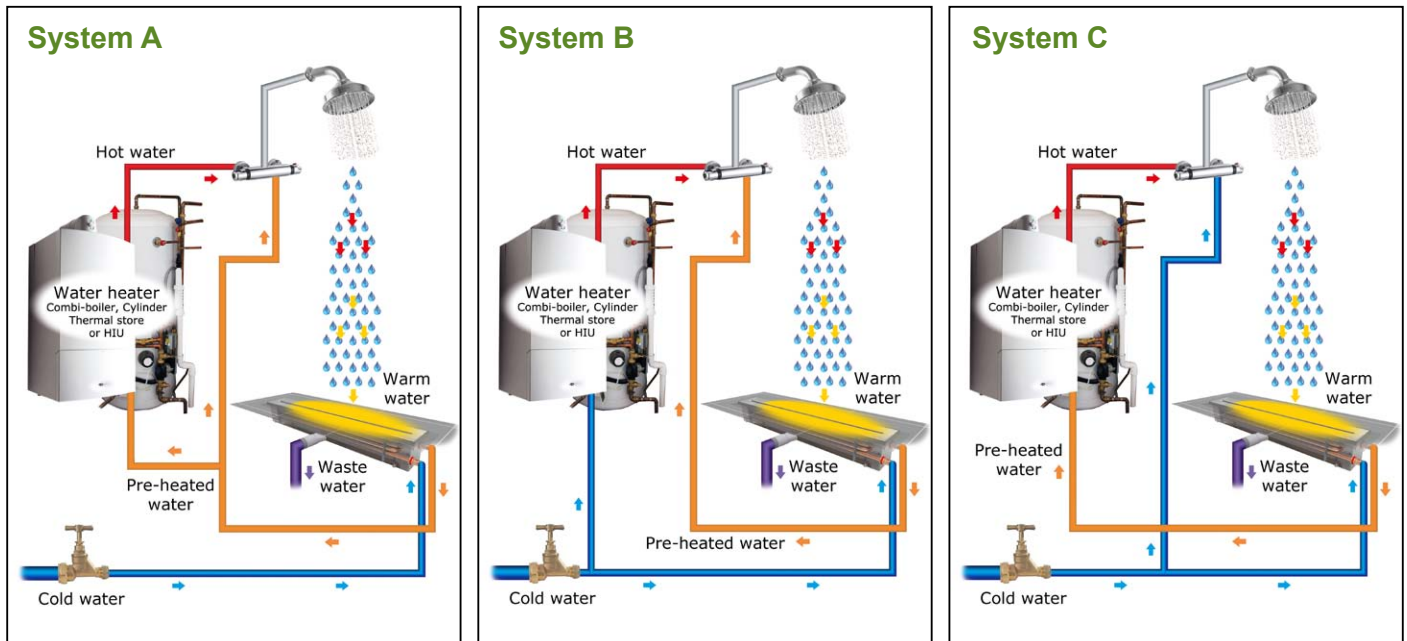

SYSTEM A – Preheated water supplied to shower mixer (Cold inlet) and DHW heater.

SYSTEM B – Preheated water supplied to shower mixer (Cold inlet) on the shower only

SYSTEM C – Preheated water supplied to DHW heater only

The performance of Systems A, B & C are all recognised within the SAP Products Characteristics Database (PCDB) for energy saving calculations, but remember that System A will produce the highest efficiencies (see section 2.b. for different system efficiencies).

3.c) Locating the RECOUP Drain+ Compact

The RECOUP Drain+ Compact needs to be installed horizontally. Installation should take place on a flat surface capable of supporting the WWHRS using the fixings provided. The location should allow for access to all parts and allow routine maintenance (E.g. Cleaning) to be carried out with relative ease.

Ensure there is a 5-10 cm gap from the long edges of the Drain+ Compact to ensure tiles can be fitted to avoid standing water in the corners of the shower room.

The RECOUP Drain+ Compact must be located within the heating envelope of the building.

The Drain+ Compact must be installed with consideration to the most recent ‘Approved document – Part H of the Building Regulations’ for preventing the ingress of foul sewer gases.

3.d) Design checklist

For recognition within the SAP calculations, the following must be complied with:-

- Consideration given to DHW delivery performance (Pressure & Flow rate)
- DHW system must be a mains pressure system
- DHW system must accept preheated water
- The RECOUP Drain+ Compact must be located within the heating envelope of the building
- The shower must be fitted with a Thermostatic Mixing Valve
- Keep the distance from the bath / shower tray to the RECOUP Drain+ Compact to within 3m to maintain a high level of efficiency by minimising heat losses in the drainage system prior to the WWHRS.
- The Preheated water supply from the RECOUP Drain+ Compact to the shower cold water inlet and water heater must be: -
 - Insulated in accordance with the ‘Building Services Compliance Guide’.
 - DO NOT INSULATE THE ACTUAL RECOUP DRAIN+ COMPACT
 - Labelled to prevent any future connection of hot water take-off points (E.g. Taps).
- Prevent the RECOUP Drain+ Compact being heated above 25°C by both external sources and from ambient temperature.
- If shut-off valves are specified they should be ‘full-flow (non-restricting) shut-off valves.
- Approved document – Part H of the Building Regulations has been consulted and an appropriate method for preventing the ingress of foul sewer smells chosen.

4. Installation of the RECOUP Drain+ Compact

Check section 3.c) for guidance on locating a suitable area for installation.

4.a) Dimensions & connections

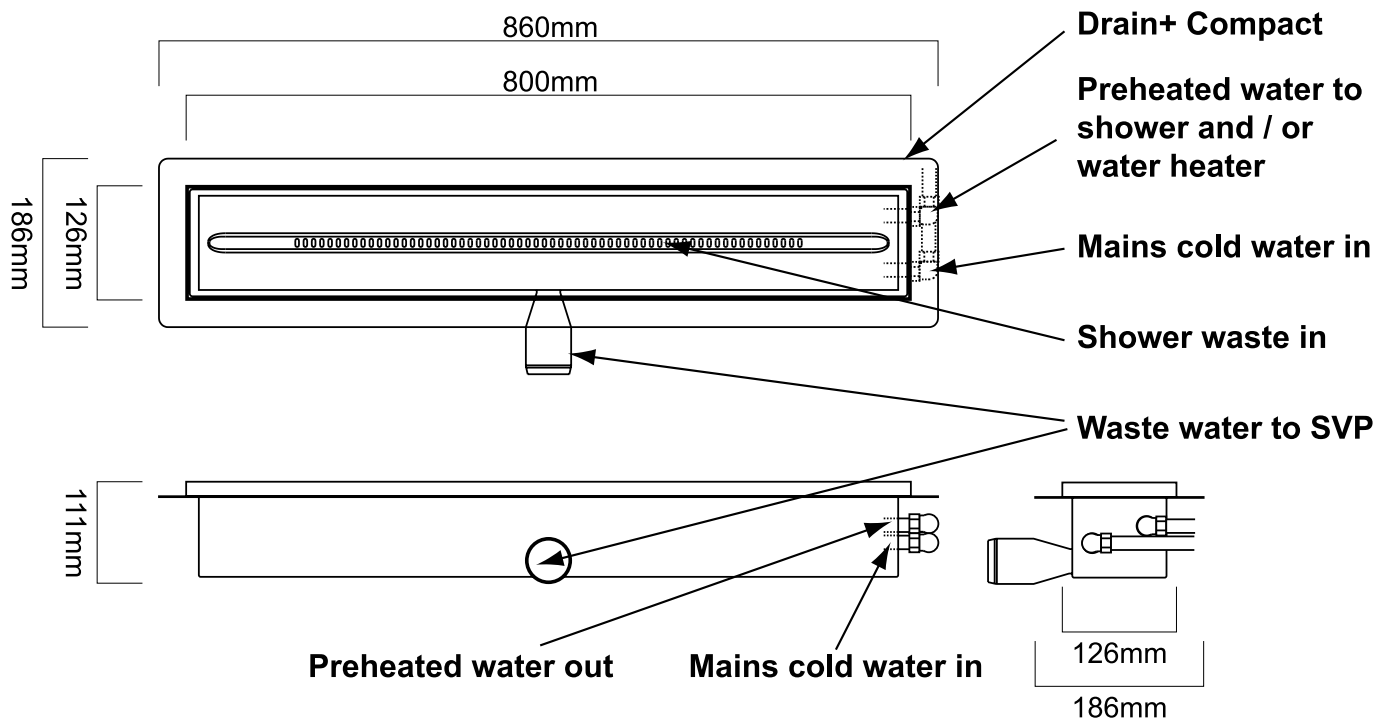

4.b) Installation contents



- 1 - RECOUP Drain+ Compact WWHRS unit
- 1a - Drain covers (Includes lid removal hook)
- 2 - Ø50mm reducer (Supplied to convert to either 43mm UK solvent or 40mm UK push-fit.)
- 3 - Straight coupling sleeve - Ø50mm
- 4 - 90° coupling sleeve - Ø50mm
- 5 - Installation instructions
- 6 - NCM (SAP) identifier label for nearby water heater or service cupboard.

4.c) Installation diagram

With straight coupling sleeve shown
& 90° coupling sleeve inset

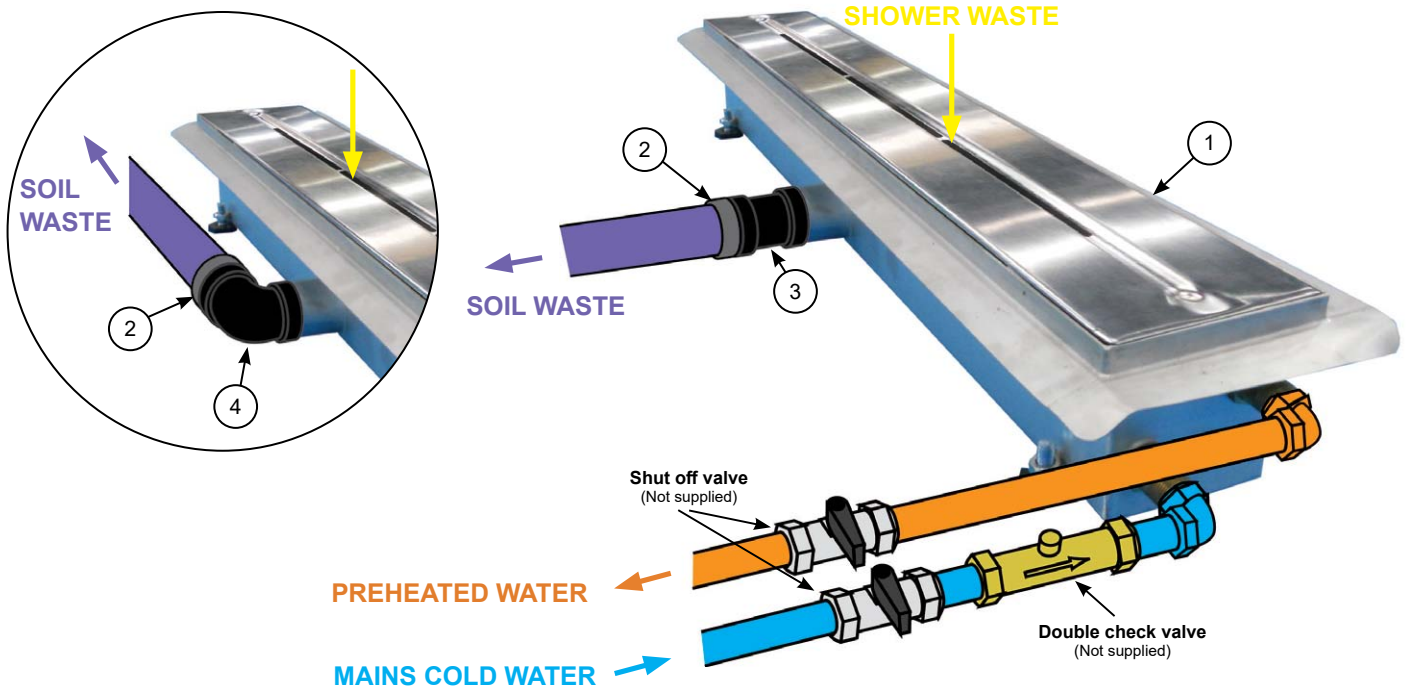

IMPORTANT NOTE

To ensure SAP compliance check buildings spec
for correct installation method (System A, B or C)

4.d) Installation process overview

While every effort is made to ensure this product arrives in optimum condition, we request that before installing the RECOUP Drain+ Compact, visually inspect the packaging and contents for signs of damage.

The unit must be installed horizontally on a suitable flat surface which is capable of holding the weight of the unit. If the mounting is not horizontal the efficiency of the unit could be reduced, installation should always be within a tolerance of +/- 10mm

The Drain+ Compact can be installed in either a concrete or wooden floor.

1. Ensure there is at least a 5-10 cm gap between the long edges of the RECOUP Drain+ Compact and the wall of the shower room.
2. Use the adjustable feet on the RECOUP Drain+ Compact to ensure that it is positioned level in all directions and that it finishes at the required floor level.
3. Connect the shower waste outlet to the sewer, using the Ø50mm straight coupling sleeve (Part 3), or the Ø50mm 90° coupling sleeve (Part 4), and Part 2 supplied to reduce 50mm European to UK 43mm solvent or 40mm push-fit.
4. Connect the mains cold water and preheated water pipework. Ensure a 1/2" Female BSP x 15mm connection is used (Not supplied), a reducer could also be used to connect to a 22mm pipe. Remember the lowest connection is the mains cold water inlet, and the highest connection is the preheated water to be connected to the shower's cold water inlet and/or water heater (Depending on installation configuration).
5. A double check valve with full flow shut off valve should be installed (Not supplied) in an accessible location on the mains cold water supply prior to the WWHRS unit. With another full flow shut off valve in an accessible location installed close to the connection for the preheated water leaving the WWHRS to facilitate any replacement of parts.
6. Check the RECOUP Drain+ Compact remains level in all directions.

7. If installing in concrete use suitable protection to protect the copper parts and connections. Use a first layer of mortar around the RECOUP Drain+ Compact and allow it to harden to fix in position. Build up floor level around the Drain+ Compact until the required floor level is achieved.

8. Once floor is dry, ensure that the flange of the RECOUP Drain+ Compact is oil free, dry and free from dust, Paste shower tape over the lid of the Drain+ Compact so it covers the flange and connects to the shower room floor, to produce a watertight connection between the Drain+ Compact and floor.

9. Tile the floor up to the Drain+ Compact leaving a 3-5 mm gap between the tiles and the lip on the Drain+ Compact.

10. Once the tiles are dry, use a sealant to seal the gap between the Drain+ Compact and the tiles.

11. Check and complete the following:

- a) Ensure the preheated water supply is only feeding the DHW water heater and the cold water inlet of the shower's thermostatic mixing valve (System A), the cold inlet of the shower's thermostatic mixing valve only (System B) or the water heater only (System C).
- b) The preheated water supply from the RECOUP Drain+ Compact is clearly labelled to avoid future connections of other services. Preheat supply tape is available for this.
- c) Pipework between the RECOUP Drain+ Compact and the water heater and/or cold water inlet of the thermostatic mixing valve is insulated.
- d) When the complete system is being checked and pressure tested, the Drain+ Compact must be isolated if the system testing is to proceed above 10 bar.
- e) Ensure the SAP label supplied correctly identifies the System installed and is applied near to the water heater in the property (Part 6).
- f) Complete the design and installation checklist or register the installation.

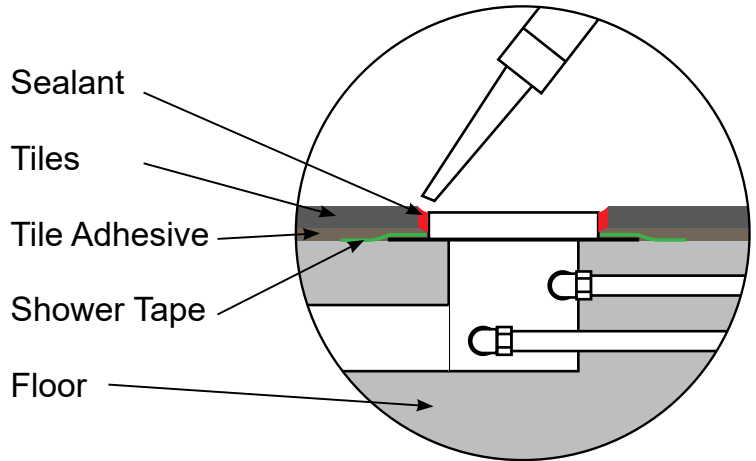

Preheat supply tape (Not supplied)



NCM (SAP) Identifier	
Technology type:	Waste Water Heat Recovery System
Technology category:	Instantaneous Shower Heat Recovery
Brand name:	RECOUP
Model qualifier:	System A / System B / System C (Delete as appropriate)
<small>This dwelling has been fitted with a Waste Water Heat Recovery System for Showers which is recognised by the Government's Standard Assessment Procedure (SAP) for Energy rating of dwellings. Note: One label must be permanently fixed to the WVHRS unit and another to a nearby Boiler or Service Cupboard.</small>	
<small>Recoup Energy Solutions Ltd, PO Box 365, Eye, IP22 9BH Register this installation on our website or via the app available on www.recoupenergysolutions.co.uk/registration</small>	

Water heater SAP identifier label

For all technical or installation queries, please contact RECOUP directly. For product related issues, please contact your place of purchase.

IMPORTANT NOTE

This document should be left with the home owners pack.

5. Legionella Risk & Protection

5.a) Double Walled Heat Exchanger

European regulations (NEN 1717) require that double walls must be used to separate drain water and drinking water. In the RECOUP Drain+ Compact, this is accomplished by squeezing two copper pipes against each other. This creates a very sturdy and reliable construction, in which the contact between the pipes does not depend on the water pressure. The design meets all the relevant safety requirements.

The RECOUP Drain+ Compact should be protected against return flow through a verifiable double check valve plus shut-off valve. It is permissible to connect the system directly to the sewer system.

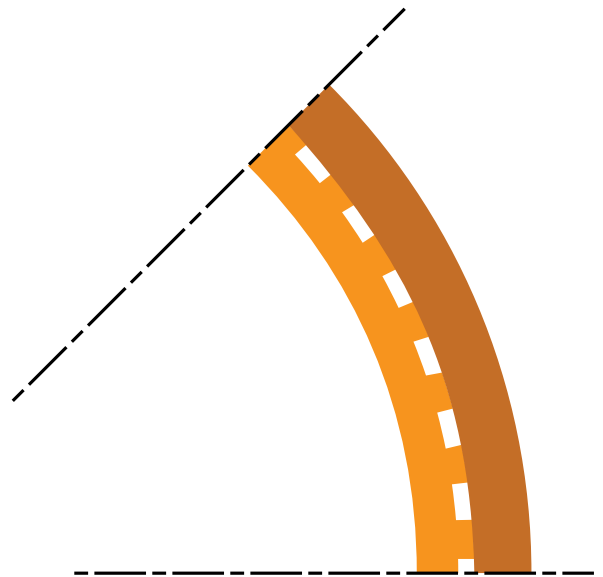

Double wall exchanger

5.b) Legionella

Consideration must be given to the potential risks of legionella bacteria growth when installing any hot water system and this includes ALL devices that are used in the production and transportation of hot water in the domestic home or commercial environment. Please refer to the following information provided covering Legionella.

5.c) Legionella Risk & Protection when installing a RECOUP WWHRS product

Care and attention must be paid to the system design to protect against the potential risk of Legionella growth within the hot water system with or without a WWHRS unit being installed. The guidance below is to highlight the potential risks that installation of a WWHRS can have on the hot & cold water supply within a property, but due to the variations in design in properties a final risk assessment needs to be carried out by the system designer and installer.

The following guidance is provided to keep the risk to a smaller level as possible, with general and specific guidance depending on the System of installation (A, B or C). Within the UK, there is no specific guidance on Legionella control within the domestic home, but the document known as HSG 274 and written for Health and Safety guidance in the work place, does in Part 2 offer guidance on the control of Legionella in water systems, some of which is aimed at recirculating hot water systems, but never the less offers good advice. The World Health Organisation (WHO) have also published a document (Last version 2007) titled 'Legionella and the prevention of Legionellosis', however, this is for information purposes only.

General guidance

For best practice the pipework between the WWHRS and the cold mixer on the shower and the boiler/hot water cylinder should be copper, as this is a material that is less susceptible to the formation of biofilm, which is a known factor in the growth of Legionella bacteria. However, if plastic / PVC plumbing has been considered suitable for the property by the installer/designer then an onsite risk assessment should be carried out to ensure the risk is minimal. If products do require flexible hoses instead of copper pipe then these must be PEX and never EPDM

It is always recommended to clean any TMV at least once every 6 months to remove the build-up of any contamination.

Showers in general can be a problem area for Legionella growth in the domestic home, and L8 recommends that shower heads are dismantled quarterly or as necessary to clean and descale them and the hoses.

The frequency that domestic showers are used in the home means that the system is flushed on a high number of occasions per week, which in itself helps in prevention of Legionella bacteria growth. It should be remembered that after any dormant periods (HSG 274 Part 2 recommends weekly flushing is acceptable as long as a risk assessment does not identify a susceptible population), it is good practice for a shower (With or without a WWHRS fitted) to be slowly flushed taking care not to create an aerosol, either by unscrewing the shower head or covering the shower head with a plastic bag and allowed to run for 3 minutes to introduce fresh water into the system. The hose on a shower from the TMV to a shower head will contain a mixture of cold and hot water, and the warming of the cold water brings it into the optimum temperature range for Legionella growth (TMV is set by the user between 36°C and 41°C). This water will cool down in time and in the domestic home be flushed through on a near daily basis, but it still introduces a risk.

System A – Delivery of preheated water to a water heater (Cylinder, combi-boiler, HIU) and the cold mixer on the TMV

If the water heater being installed is a hot water cylinder that will raise the temperature to 60°C for a period longer than 10 minutes, then the distance of pipe from the WWHRS to the cylinder doesn't matter with regard to Legionella, as the preheated water in the pipe will on entering the cylinder be raised to sufficient temperature to kill any bacteria (Note: that for energy efficiency this distance should still be kept to a minimum).

If a combination boiler or HIU (Heat Interface Unit) is being used then it should be capable of heating the preheated water to 60°C and holding it at that temperature for greater than 10 minutes, so any potential growth within stagnant pre-heated water from the previous shower is raised to a level where the Legionella bacteria can be killed. Any water heater used in the domestic home that does not raise hot water above 60°C for this period of time is introducing the same level of risk to the system (With or without a WWHRS), and these risks need to be assessed in terms of the level and frequency of usage, and whether the device is used for stored or instantaneous hot water.

For System A there is also a feed of the pre-heated water straight to the cold inlet of the TMV. Regardless of the water heater that is installed in the installation, the pre-heated water (25°C) that remains between the WWHRS and the TMV will not be re-heated, so can never pass a temperature of 60°C, and therefore introduces the same level of risk to the system as any instantaneous water heater that does not achieve 60°C would do. HSG 274 Part 2 recommends that all cold water supplies should be kept to 20°C or below, however, it does note that the Water Supply (Water Quality) Regulations do permit water utilities to supply water to premises at temperatures up to 25°C, but due to the climate in the UK this is not likely, except in summer. Table 3: Monitoring the temperature control regime, of HSG 274 Part 2 states that the standard to meet for cold water on a monthly basis is that a temperature of below 20°C should be reached after running the water for up to 2 minutes. Therefore, it is suggested that the pipe run from the WWHRS to the cold inlet of the TMV is kept as short as possible, and no greater than 4.75 meters.

Users of the shower could additionally run the shower for 15 seconds after showering on the cold setting of the TMV to flush through the remaining pre-heated water. As mentioned in the general section, the regular use of showers in the domestic home means flushing happens on a regular occasion, however, prior to periods of non-use (E.g. Holiday), this practice would be advisable.

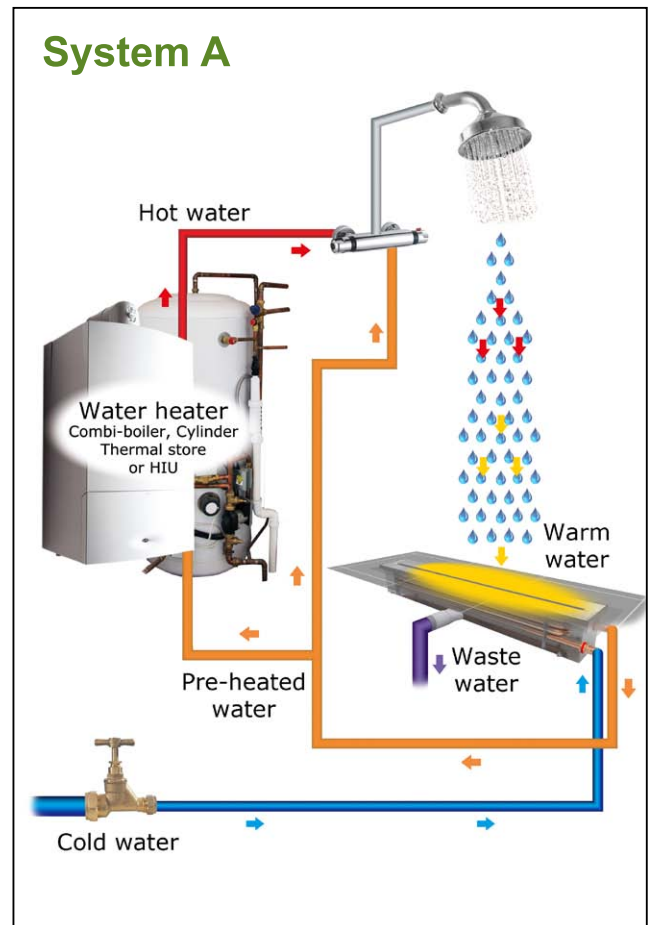

5.c) Legionella Risk & Protection continued from reverse pages ◀

To further protect the system from potential risk of legionella growth, the installation of a device from Kemper (KHS-Multi-Circ Distributor Unit) will reduce the amount of stagnation that occurs in the pre-heated pipe from the WWHRS to the cold inlet of the TMV, as each time a hot water outlet in the property is opened a small circulation will be created within the water (basic details below, and more information on www.kemper-valves.com)

The flow distributor's operation is based on the principle of the Venturi nozzle. The minimum pressure difference between Supply line A and Return line B causes an induced flow in the branch. The drive comes from water removal after the KHS-Multi-Circ Distributor Unit. The entire water content in the branch is thus changed, stagnation is prevented and the water temperature is kept low.

Taken from...

http://www.kempervalves.com/pdf/pdf%20englisch/khs_20s_engl_07_10.pdf

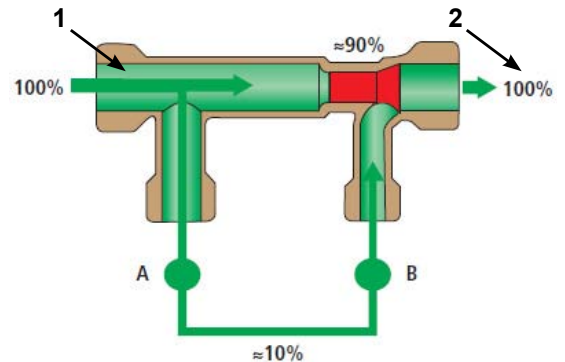

1. The pre-heated water from the WWHRS before it splits to the water heater and the cold inlet of the shower TMV.
 - A. The split of the pre-heated water, with 'A' going to the cold inlet of the TMV for the shower.
 - B. A return loop taken from as close to the TMV as possible and back into the valve
2. Continues to the water heater

System B Installation – Cold inlet on the TMV only

This installation provides the highest risk of the three installation methods.

Regardless of the water heater that is installed in the installation, the pre-heated water (25°C) that remains between the WWHRS and TMV will not be re-heated, so can never pass a temperature of 60°C, and therefore introduces the same level of risk to the system as any instantaneous water heater that does not achieve 60°C would do. HSG 274 Part 2 recommends that all cold water supplies should be kept to 20°C or below, however, it does note that the Water Supply (Water Quality) Regulations do permit water utilities to supply water to premises at temperatures up to 25°C, but due to the climate in the UK this is not likely, except in summer. Table 3: Monitoring the temperature control regime, of HSG 274 Part 2 states that the standard to meet for cold water on a monthly basis is that a temperature of below 20°C should be reached after running the water for up to 2 minutes. Therefore, it is suggested that the pipe run from the WWHRS to the cold inlet of the TMV is kept as short as possible, and no greater than 4.75 meters.

It should be noted that the pre-heated water is never stored and maintained at the 25°C temperature, therefore, even though still a risk to consider if the system is to be used/flushed frequently this will be in line with guidance in HSG 274 Part 2 for treatment of the mixed water after the TMV which is also water containing cold water that has been heated above 20°C but not past 60°C (Along with the guidance in the general section for general maintenance of a shower with or without a WWHRS installed).

Users of the shower could additionally run the shower for 15 seconds after showering on the cold setting of the TMV to flush through the remaining pre-heated water. As mentioned in the general section, the regular use of showers in the domestic home means flushing happens on a regular occasion, however, prior to periods of non-use (E.g. Holiday), this practice would be advisable.

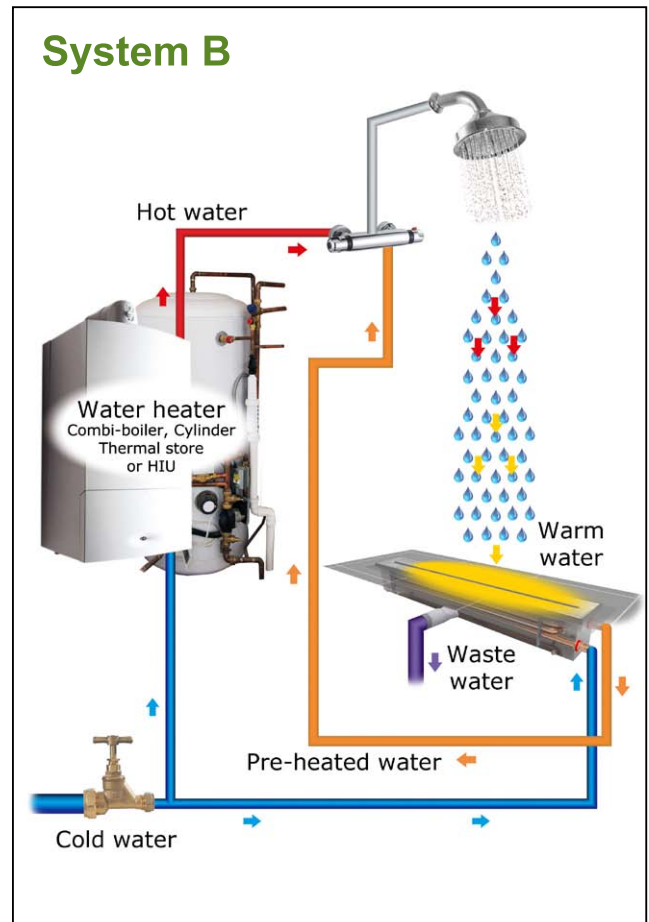

System C Installation – Feed to water heater only

This is the lowest risk of all the installation methods.

If the water heater being installed is a hot water cylinder that will raise the temperature to 60°C for greater than 10 minutes, then the distance of pipe from the WWHRS to the cylinder doesn't matter with regard to Legionella, as the preheated water in the pipe will on entering the cylinder be raised to sufficient temperature to kill any bacteria (Note: that for energy efficiency this distance should still be kept to a minimum).

If a combination boiler or HIU (Heat Interface Unit) is being used then it should be capable of heating the preheated water to 60°C and holding it at that temperature for greater than 10 minutes, so any potential growth within stagnant pre-heated water from the previous shower is raised to a level where the Legionella bacteria can be killed. Any water heater used in the domestic home that does not raise hot water above 60°C for this period of time is introducing the same level of risk to the system (With or without a WWHRS), and these risks need to be assessed in terms of the level and frequency of usage, and whether the device is used for stored or instantaneous hot water.

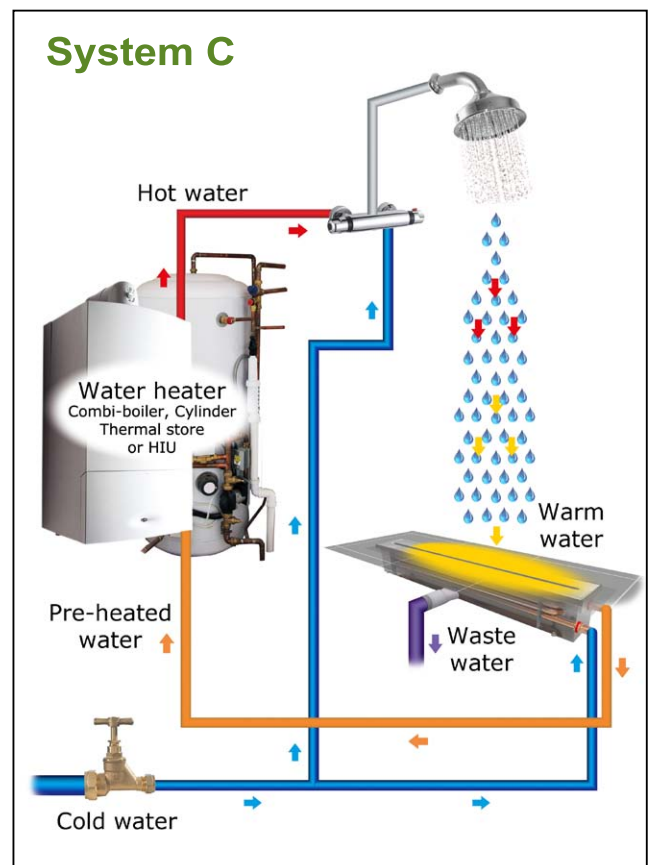

6. Maintenance

The maintenance required for the RECOUP Drain+ Compact is very minimal, however, it is recommended to clean the unit periodically to avoid any reduction in efficiency. This cleaning will remove any build-up of soap and dirt residue on the inside of the copper pipe where the waste water passes.

To clean, remove the Drain+ Compact lid (Grate) with the provided hook (Take care as Stainless steel can be susceptible to scratching). Ensure that the lid and the distribution plate below are clear of debris, as the distribution plate is vital in maintaining the efficiency of the RECOUP Drain+ Compact. If required, the copper heat exchanger can also be cleaned using a soft brush and if needed, some household degreaser in a spray bottle. Once cleaned, replace the lid and rinse thoroughly with warm water from the shower.

7. Warranty

The RECOUP Drain+ Compact comes with a 2 year warranty unless agreed otherwise. This starts from either the date of invoice from Recoup Energy Solutions Ltd or the date of installation recorded on the received SAP documentation in line with the SAP Design and Installation Checklist.

This warranty is conditional on the product being installed in accordance with these instructions (Installation and ALL requirements for SAP, if product is to be recognised for Energy efficiency calculations), correct plumbing practices and Building Regulations.

8. Registration

The installation of a WWHRS should be registered to comply with SAP requirements. Registration can be completed by filling in a downloadable paper based design and installation checklist, returning it to RECOUP with copies completed for the homeowner and your records. Alternatively, you can download the RECOUP WWHRS App which provides customers and installers with an easy to use and access registration facility.

Visit registration.recoupwwhrs.co.uk or scan the QR code to download our Apple or Android registration App, or download and print the paper based design and installation checklist. Post completed paper based manual documents to...

Recoup Energy Solutions Ltd, PO Box 365, Eye, IP22 9BH



IMPORTANT PLEASE REGISTER

**The installation of this WWHRs should be registered
to comply with SAP requirements.**

Visit our website registration page

[REGISTRATION.RECOUPWWHRS.CO.UK](https://www.recoupwwhrs.co.uk/registration)

or scan the QR code to download our Apple or Android registration App.



Alternatively download and complete the paper registration document and return it to us at Recoup Energy Solutions Ltd, PO Box 365, IP22 9BH

E: INFO@RECOUPWWHRS.CO.UK

T: 01379 844010

W: [RECOUPWWHRS.CO.UK](https://www.recoupwwhrs.co.uk)

